

# CITY OF ALBANY SIGNAGE SYSTEM STRATEGY Style Guide + Technical Specifications

/ Developed by Jetblack & Tim Waters

---

VERSION 16  
04-02-21

---



COPYRIGHT 2018, CITY OF ALBANY  
CP.DEC.30 / NG21140517





## CONTENTS

---

1.0 _ DIRECTION	3
2.0 _ SIGNAGE SUITE	4
3.0 _ TYPOGRAPHY	7
4.0 _ COLOUR	9
5.0 _ FORM CHARACTERISTICS	10
6.0 _ ARCHITECTURALS	18
7.0 _ SUPPORTING DOCUMENTATION	25

### DOCUMENT STATUS \ REVISIONS

04-02-2021	Content Update	- technical specifications - additional sign types
------------	----------------	---



## DIRECTION

## ENVIRONMENTAL CONNECTION

This buried cube is clad in a distinct material to reflect the precinct in which it resides and to reinforce the concept highlighting this submerged part of the sign.



## EROSION TO REVEAL

The City of Albany is an etched arts-cape, exhibiting a truly unique topography. At the heart of this unique landscape are rock formations shaped by years of erosion which has revealed the diverse and beautiful granite

## STACKED CUBES

Sign suite is based on stacked cubes with the base cube 1/2 submerged to express the erosion to reveal concept.

# SIGNAGE SUITE

BIRDS-EYE + PROFILE VIEW

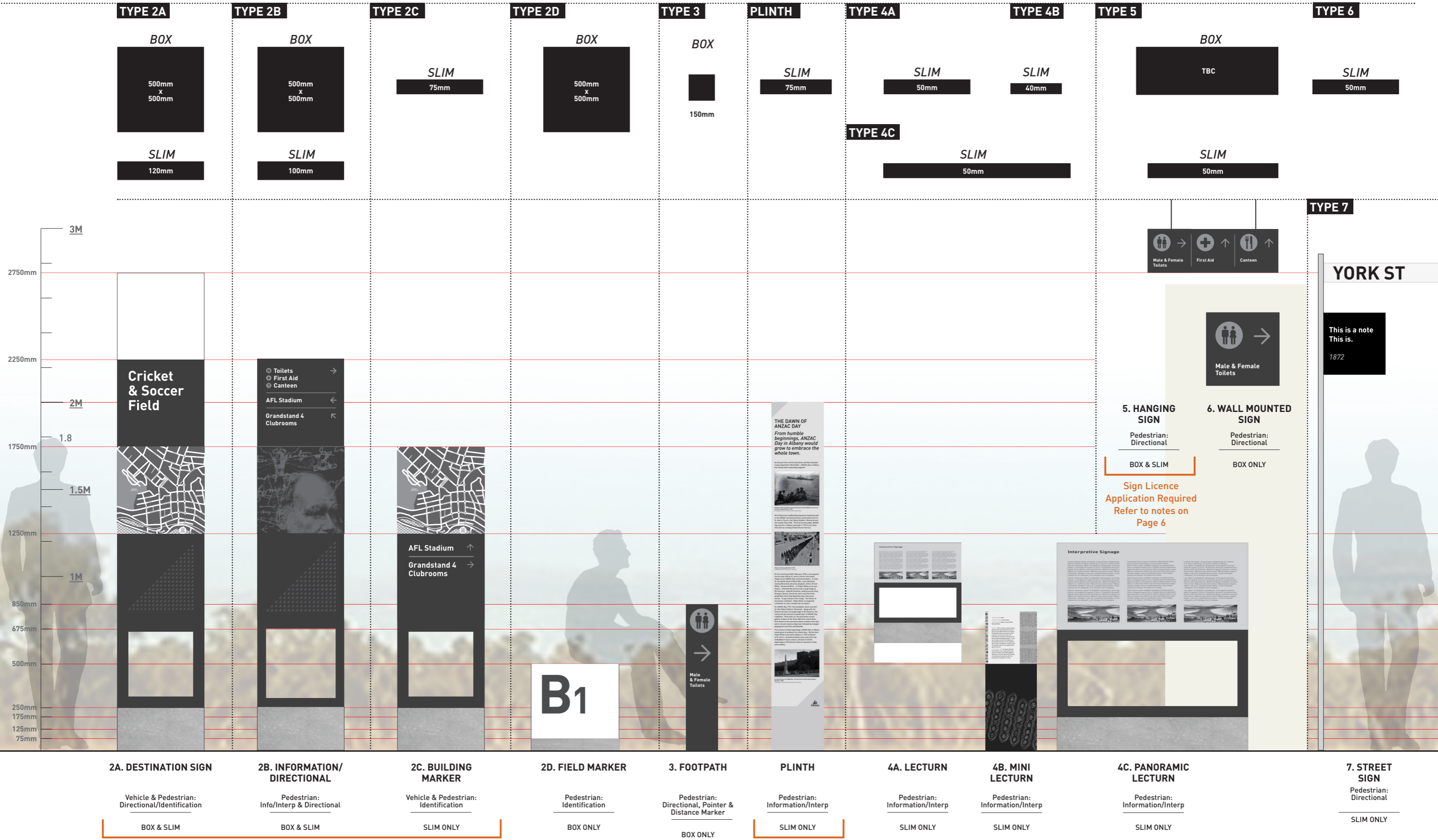

Sign Licence Application Required  
Refer to notes on Page 6

Sign Licence Application Required  
Refer to notes on Page 6

TYPE 1

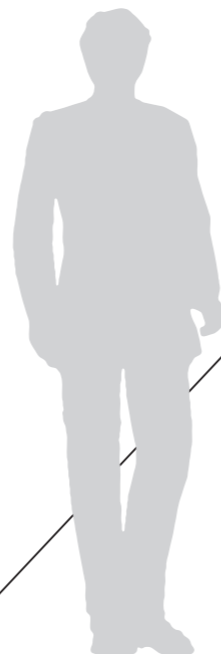

NOTE: DESIGN TO BE CONFIRMED - FURTHER  
DESIGN DEVELOPMENT REQUIRED.

TYPE 1  
PRICINCT ENTRY SIGN  
Vehicle & Pedestrian:  
Identification

CENTENNIAL  
PARK

**TYPE 2A**



**TYPE 2a DESTINATION SIGN BOX VERSION**  
Vehicle & Pedestrian:  
Directional/Identification

**TYPE 2B**



**TYPE 2b INFORMATION/DIRECTIONAL BOX VERSION**  
Pedestrian:  
Info/Interp & Directional

**TYPE 2C**



**TYPE 2c BUILDING MARKER SLIM VERSION**  
Vehicle & Pedestrian:  
Identification

**TYPE 5**

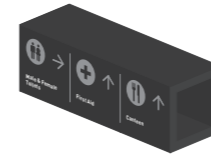

**TYPE 5a HANGING SIGN BOX VERSION**  
Pedestrian:  
Directional



**TYPE 5b HANGING SIGN SLIM VERSION**  
Pedestrian:  
Directional

**TYPE 6**

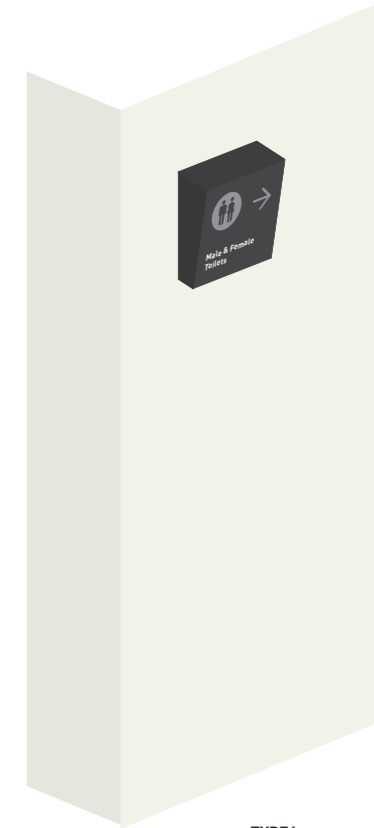

**TYPE 6 WALL MOUNTED SIGN**  
Pedestrian:  
Directional

**TYPE 2D**



**TYPE 2d FIELD MARKER BOX VERSION**  
Pedestrian:  
Identification

**TYPE 3**



**TYPE 3 FOOTPATH SIGN BOX VERSION**  
Pedestrian:  
Directional, Pointer & Distance Marker



**TYPE 2a DESTINATION SIGN SLIM VERSION**  
Vehicle & Pedestrian:  
Directional



**TYPE 2b INFORMATION/DIRECTIONAL SLIM VERSION**  
Pedestrian:  
Info/Interp & Directional

**PLINTH**



**PLINTH INFORMATION SIGN SLIM VERSION**  
Pedestrian:  
Information/Interp

**TYPE 4A**



**TYPE 4a LECTURN SIGN SLIM VERSION**  
Pedestrian:  
Information/Interp

**TYPE 4B**



**TYPE 4b MINI LECTURN SIGN SLIM VERSION**  
Pedestrian:  
Information/Interp

**TYPE 4C**



**TYPE 4c PANORAMA LECTURN SIGN SLIM VERSION**  
Pedestrian:  
Information/Interp

**NOTES:**

- Installation of signs may be subject to Planning Approval.
- No Certificate of Design Compliance or Building Permit required.
- All footings to be engineered.
- Type 2a, 2b, 2c, Type 5 and Plinth require a Sign Licence
- Sign Licence application required through City of Albany Building Department, approximately \$70per sign (when within lot boundary/reserve).
- If within road reserve, no licence required, but signs must comply with Australian Standards for construction within road reserve.
- Type 5 Hanging and Type 6 Wall Mounted signs must be 2750mm clear above footpaths.

FONT FAMILY

DIN



PLACE NAMING

DIN - BOLD

*Titlecase*

*Leading: Auto*

*Tracking: 0*

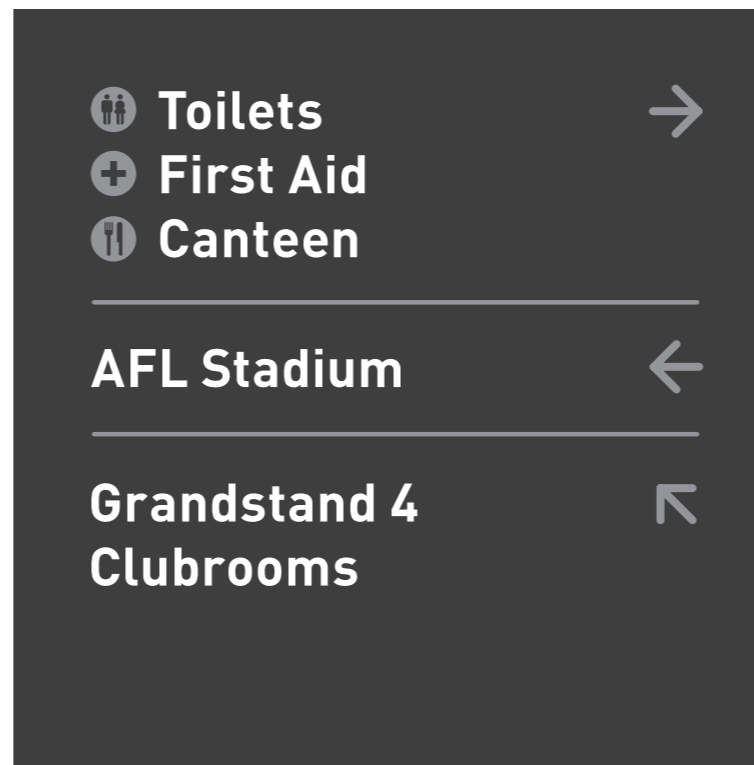

DIRECTIONAL / INFORMATIONAL

DIN - MEDIUM

*Titlecase*

*Leading: Auto*

*Tracking: 0*

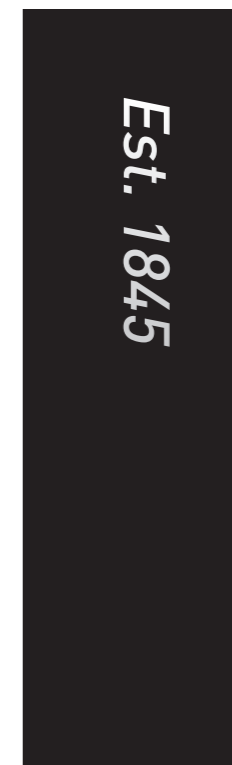

QUOTATION / PLACE SIGNIFICANCE

DIN - MEDIUM ITALIC

*Titlecase*

*Leading: Auto*

*Tracking: 0*

240pt  
Approximate Max  
Viewing Distance: 30m

Cricket  
& Soccer  
Field

Line Thickness:  
3mm

100pt  
Approximate Max  
Viewing Distance: 10m

Toilets  
First Aid  
Canteen

30x30mm  
Icon & Arrow

AFL Stadium

Grandstand 4  
Clubrooms



Mens Shed

300pt  
Approximate Max  
Viewing Distance: 40m

30pt  
Approximate Max  
Viewing Distance: 5m

60pt  
Approximate Max  
Viewing Distance: 8m

70pt  
Approximate Max  
Viewing Distance: 8m

100x100mm  
Icon

Line Thickness:  
2mm

50x50mm  
Icon

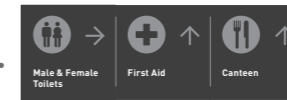

100pt  
Approximate Max  
Viewing Distance: 12m



Male & Female  
Toilets

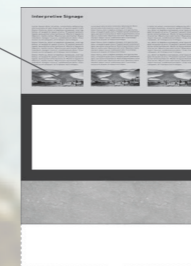



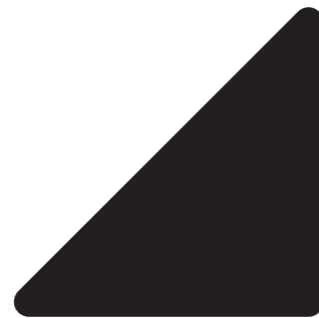

**BLACK**

---

BASE SYSTEM



**DARK GREY  
85% BLACK**

---

TRIANGULATION PATTERN -  
WHEN USED AS A BALANCING  
DESIGN ELEMENT

WATER MARK GRAPHIC



**SILVER**

---

LINE SEPERATIONS

ICONS

SUB-HEADING OR SUB-  
LEVEL INFORMATION

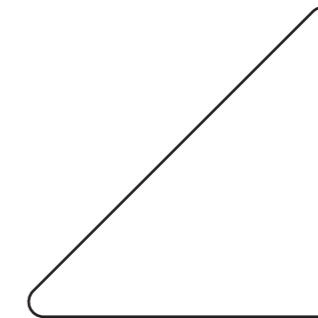

**WHITE**

---

DIRECTIONAL NAMING

BODY COPY

WHEN MAXIMUM  
READABILITY IS  
REQUIRED



**FORM**

---



## 1-TO-1 RATIO

The signage suite faces are predominately designed to a 1-to-1 ratio, with the exception being the lectern and footpath sign systems. The purpose being a modular system that allows expansion and an adaptable visual scaling to differing environment needs.

TYPE 2A

TYPE 2B

TYPE 2C

TYPE 3

TYPE 4A

TYPE 4B

TYPE 4C

TYPE 5

TYPE 6

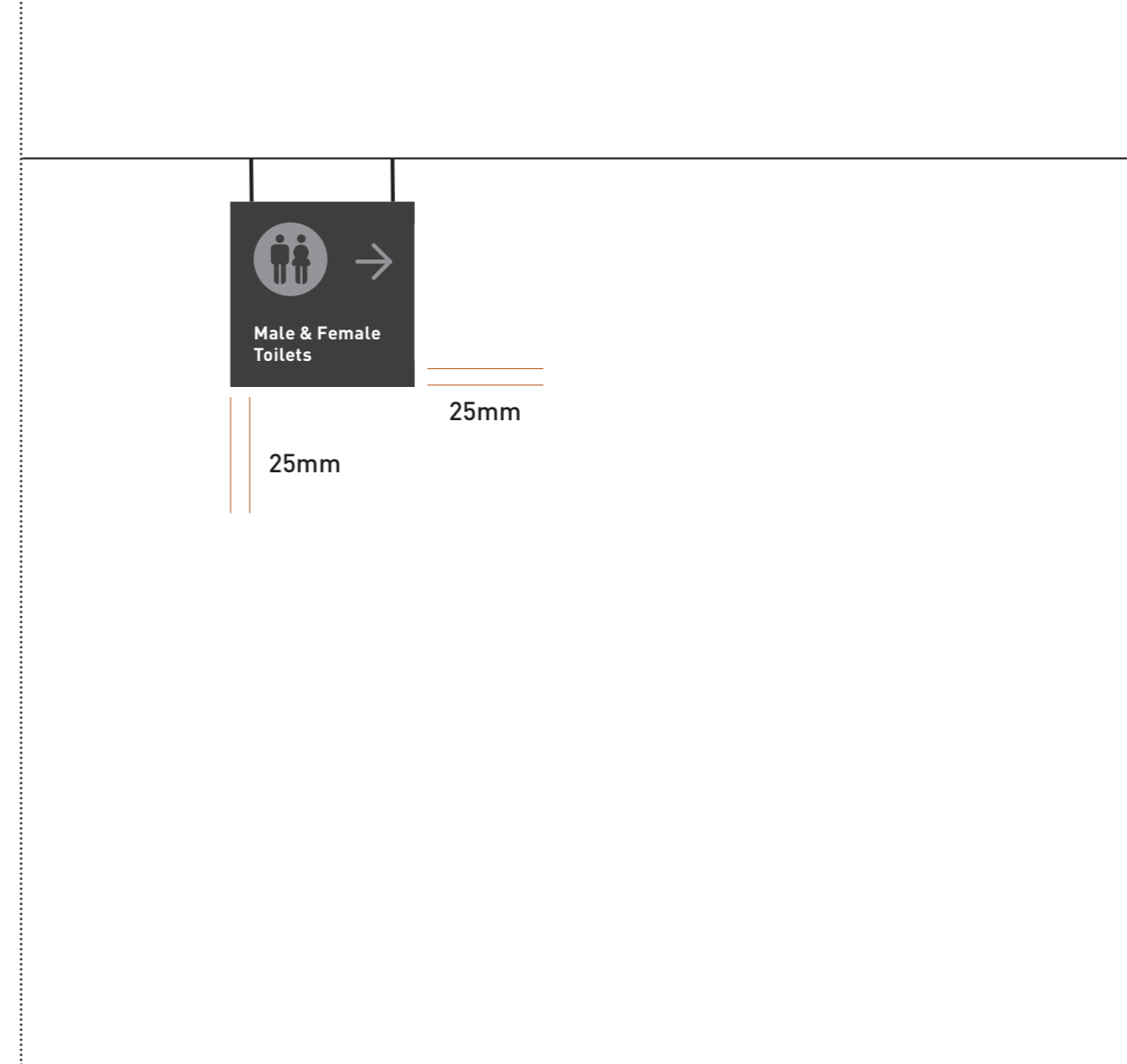
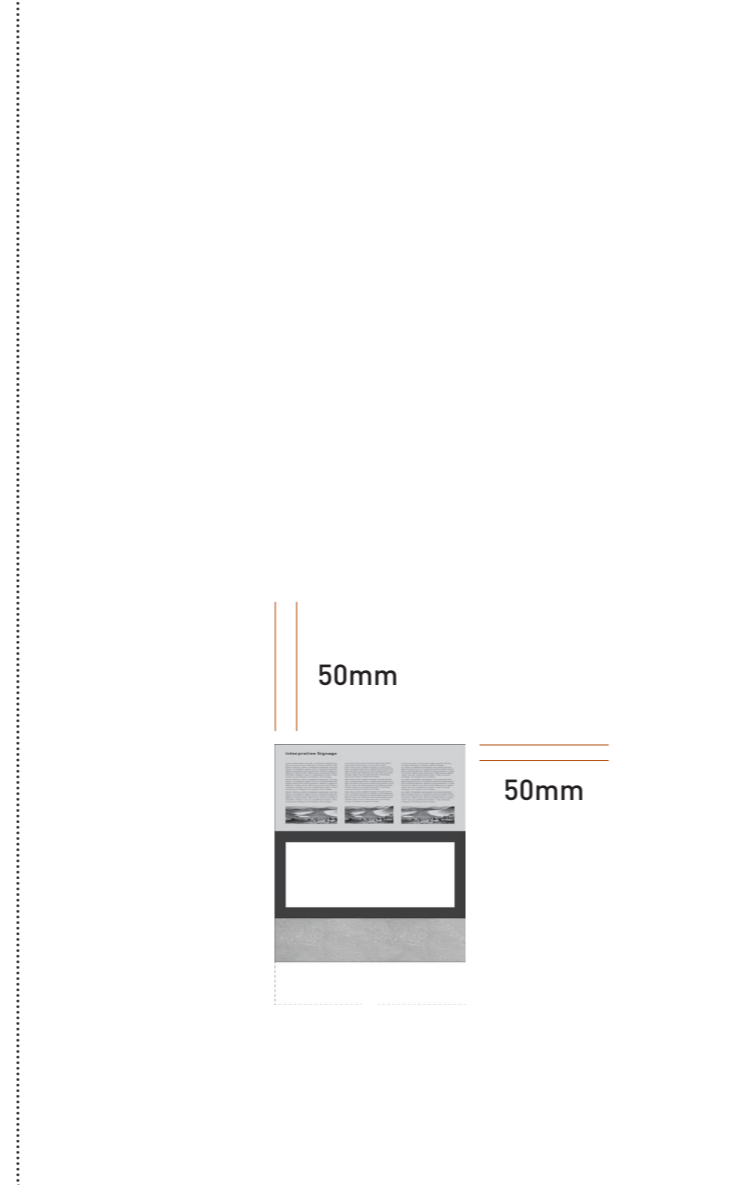
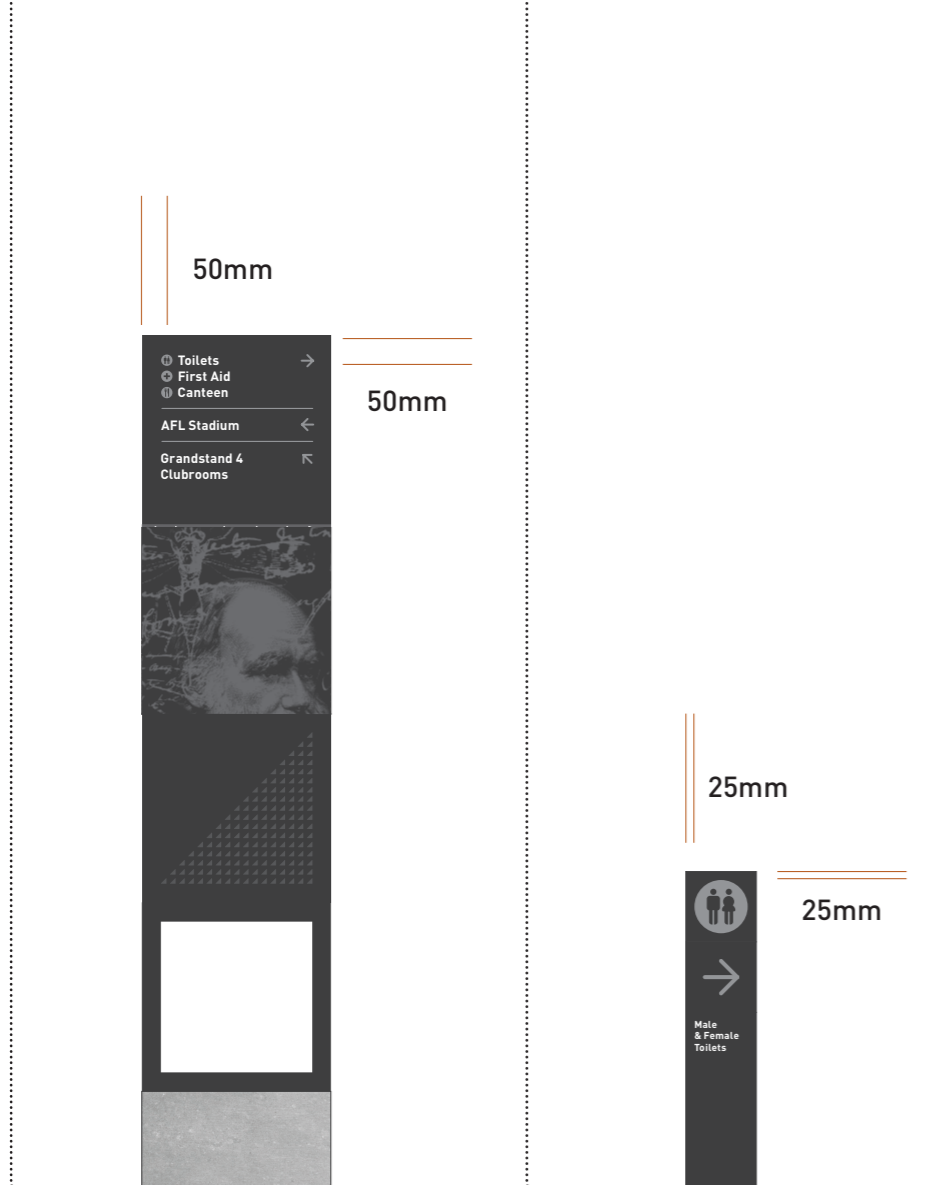

## RESPECT OF MARGINS

Respecting visual margins is important for the effectiveness of the signage suite. The 'cut-out voids' form a visual perception of margins to be used. These vary between 50 and 25mm depending on the system.

## TRIANGULAR PATTERN



### USE 1: FACE FILLER

The triangular pattern is to be used in the boxed & slimline systems. A subtle texture to add depth and interest to the signage suite.

Up to 3 triangular patterns to be used - positioned to the adjacent faces to 'cut-out' sections.



### USE 2: BALANCING AGENT

Used in cases of vertical type (Place Naming) or in rare cases where balancing is required on directional signage.

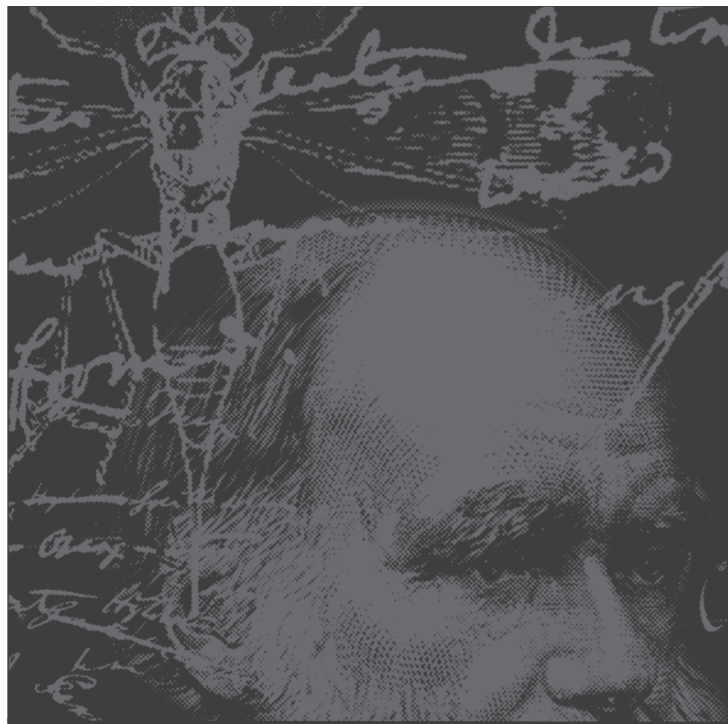

## OVERLAY

As evident in 'Charles Darwin' signage a subtle 'watermark' graphic can feature as a graphic face. Tonality must be of a similar nature to the 85% dark grey triangulated feature.  
Digital print graphic

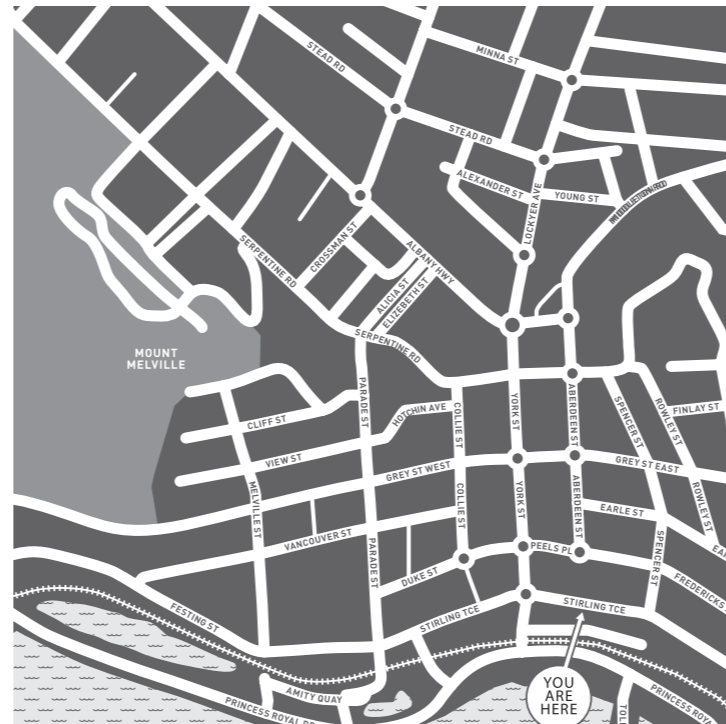

## MAP STYLING

As mentioned previously, maps are the only exception to the margin rule. Maps are to bleed to edges of sign system.  
Digital print graphic

Map style and graphics approved for use are appended to the Supported Documentation section.

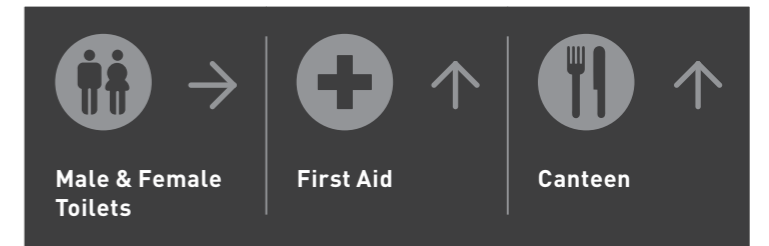

## ICONS

A suite of icons approved for use are appended to the supported documentation section.  
For large scale icons - mask and spray

SLIMLINE

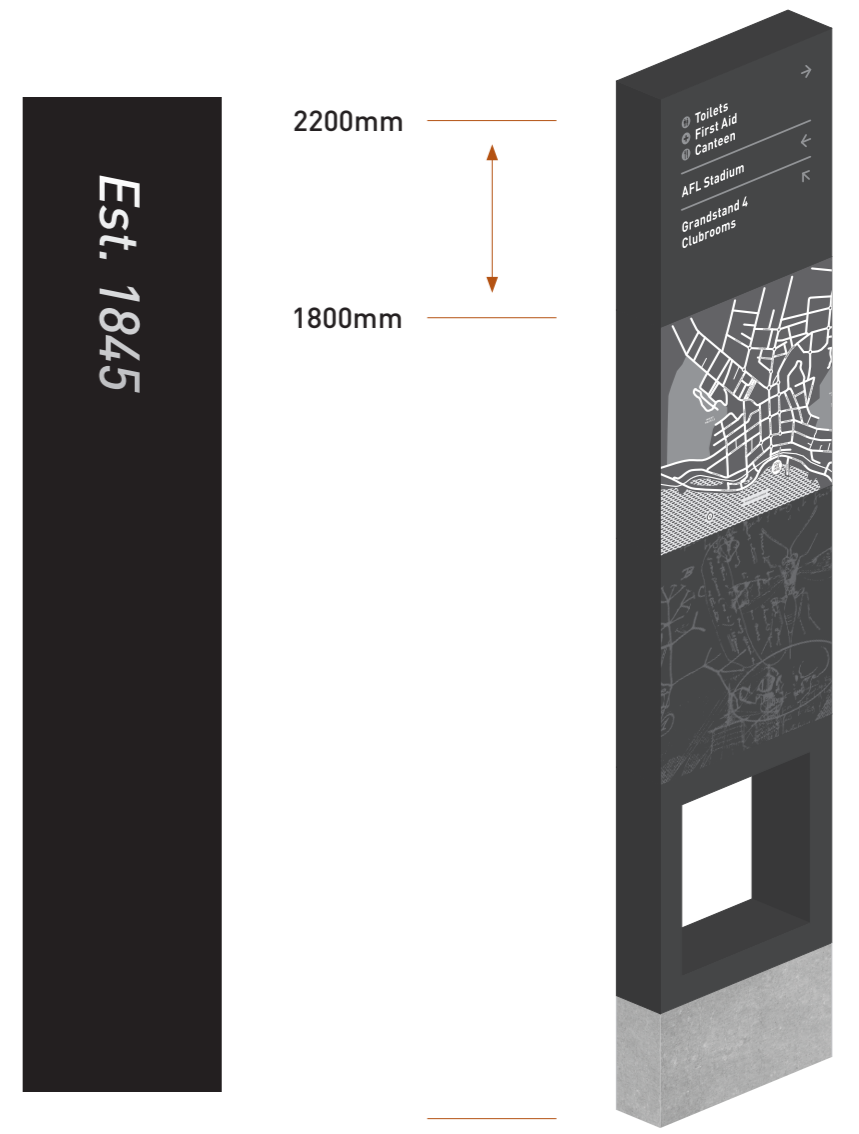
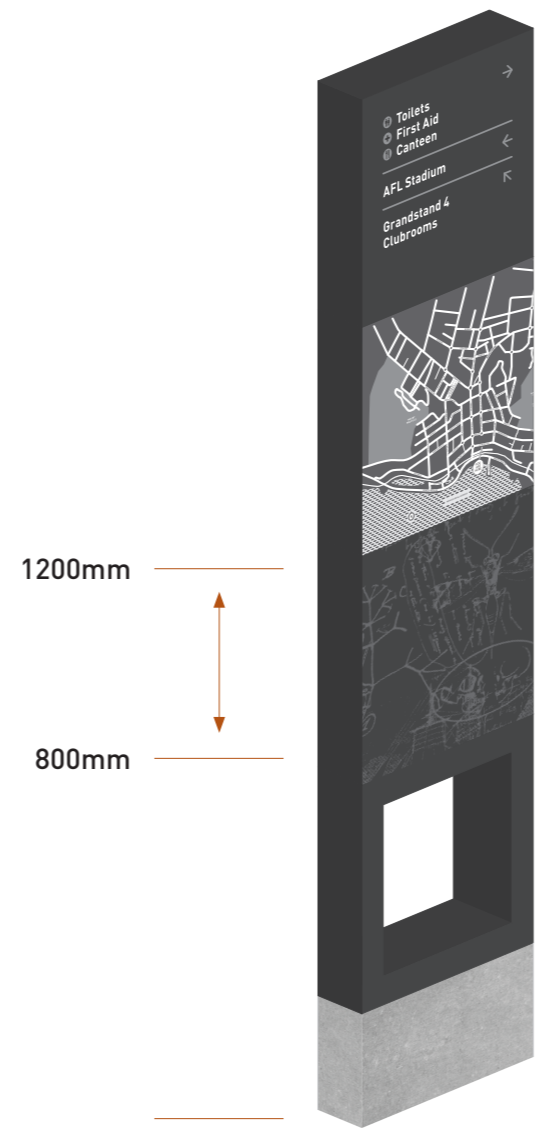
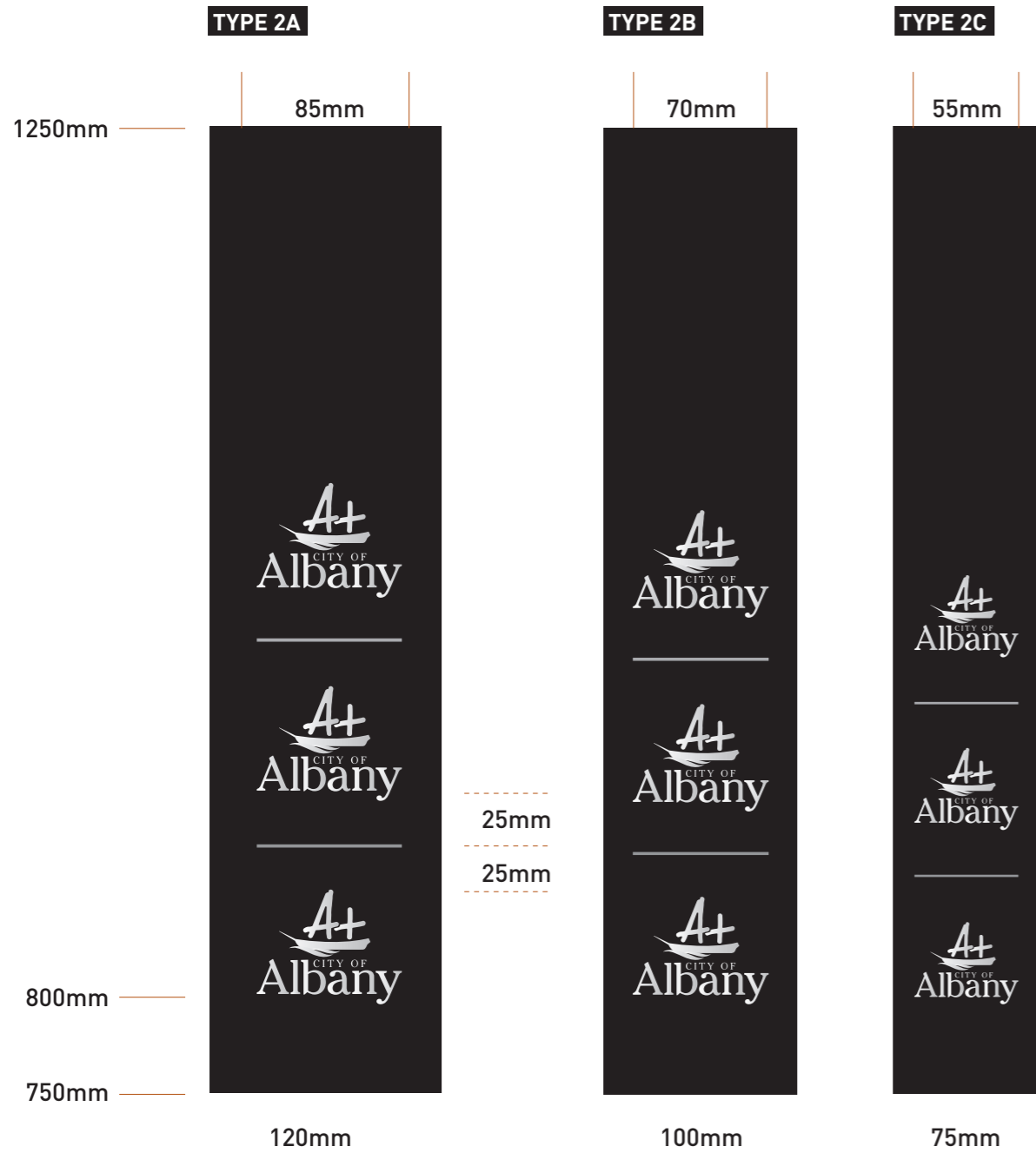

LOGOS

Single Colour - Silver  
 Width 55mm, horizontally centred  
 50mm spacing between logos with central line separator  
 MAXIMUM of 3 logos per side

CULTURAL SIGNIFICANCE

Single Colour - Silver  
 Short statement at a maximum length of 400mm  
 Din-Medium Italic, 80pt  
 Horizontally centred

### MATT 2-PAC FINISH

Substrate sprayed in 2-pac matt paint

### NANOKOTE

NANOKOTE ECO BARRIER - NK-M1 MATT FINISH

\*No warranty provided unless applied by accredited Nanokote applicant

### EDGING

SEAMLESS SQUARE EDGE - Filled (using adhesive e.g. sikaflex - no bog), sanded & smooth butt joins to create a seamless look and feel.

### SHADOW LINES

4mm shadow lines at each 500mm intersection accentuate the boxed visual. Shadow lines on 500mm width faces only, not on narrow side of slim line signs

### CLEANING / MAINTENANCE

All frames acid cleaned before paint application  
Damaged faces can be re-skinned with 0.6mm aluminum sheet  
Wipe down properly with a damp rag minimum 2 times per year (particularly for any box cubed sign with shadow lines)

### BASE / PLINTH CLADDING

Sign structure is based on stacked cubes with the base cube submerged to express the erosion to reveal concept. Plinth cladding dependant on environmental location. Please see corresponding page.

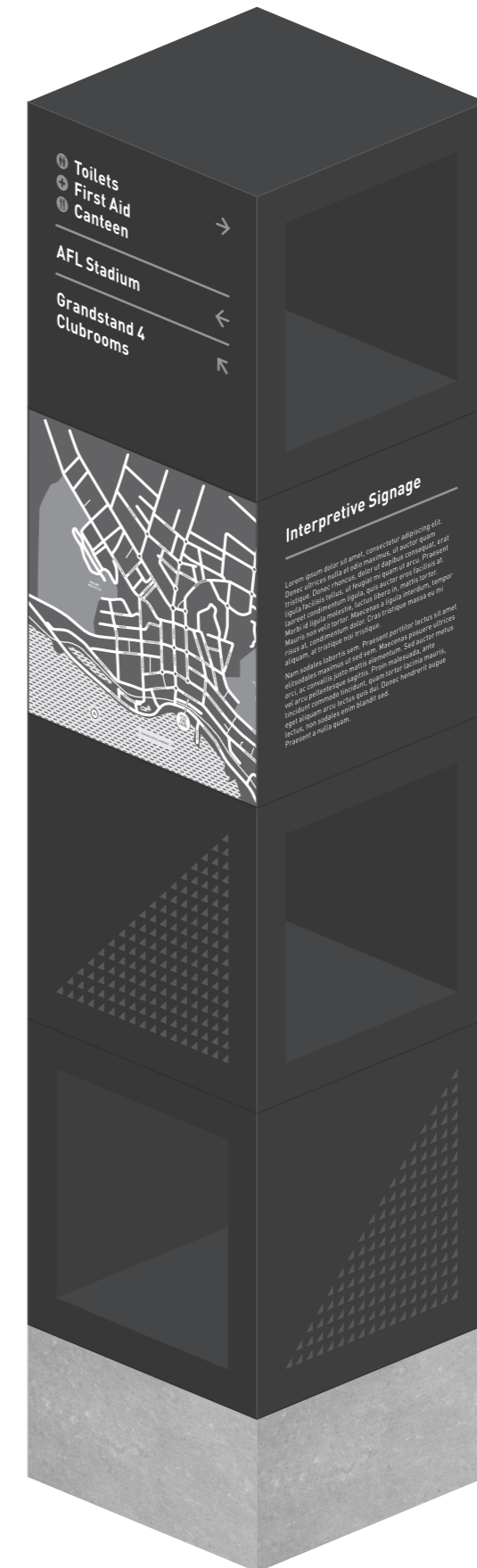



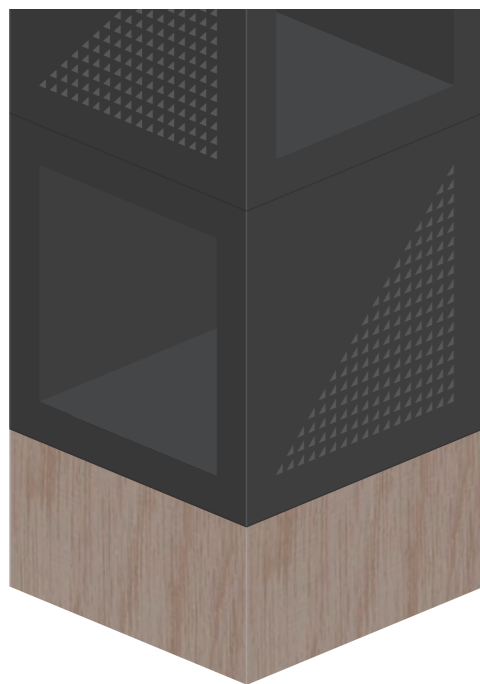

**COASTAL  
CORETEN**

Only to be installed in grass/dirt areas due to colour leaching

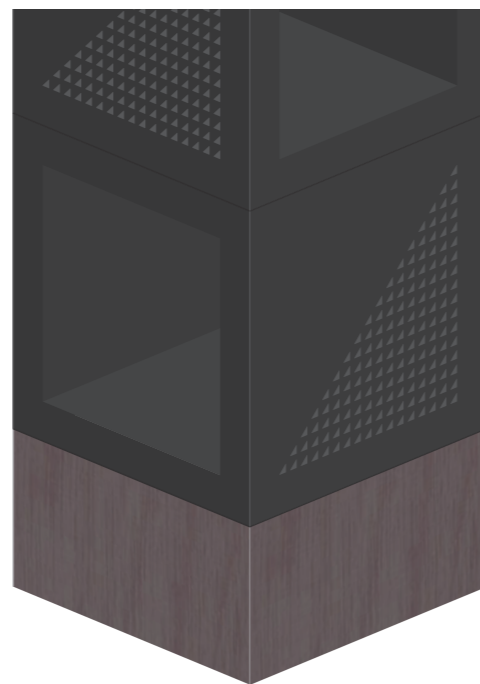

**INLAND  
COMPOSITE TIMBER - DARK STAIN**

Samples to be provided if requested for use

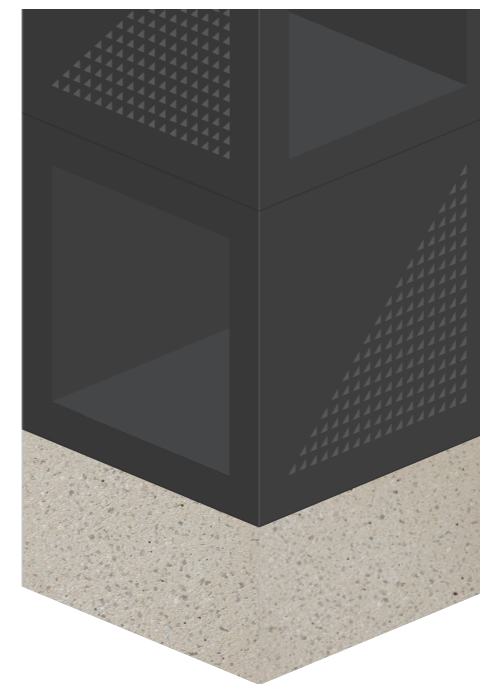

**URBAN  
COMPRESSED FIBRE CEMENT  
SHEETING OR TILE**

To be agreed on case by case basis

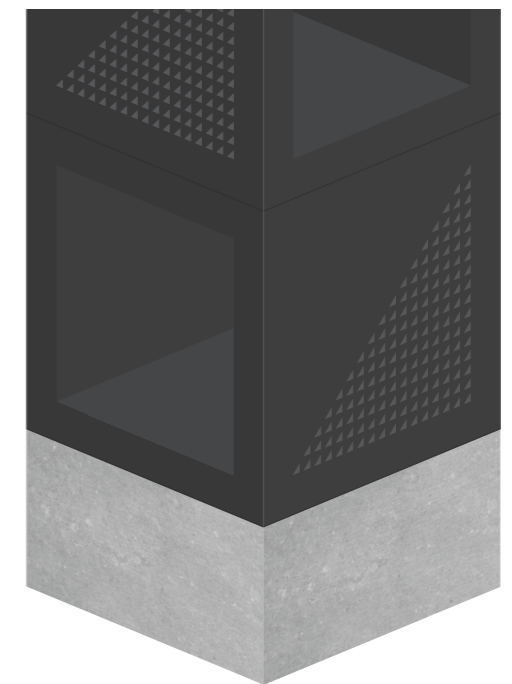

**SPORT & REC  
COMPRESSED FIBRE  
CEMENT SHEETING**

Equitone CFC sheeting (10mm thick) and coated with Guardian sacrificial anti-graffiti coating

The buried 'plinth' cube is clad in a distinct material to reflect the precinct in which it resides and to reinforce the concept highlighting this submerged element of the sign system.



# ARCHITECTURALS

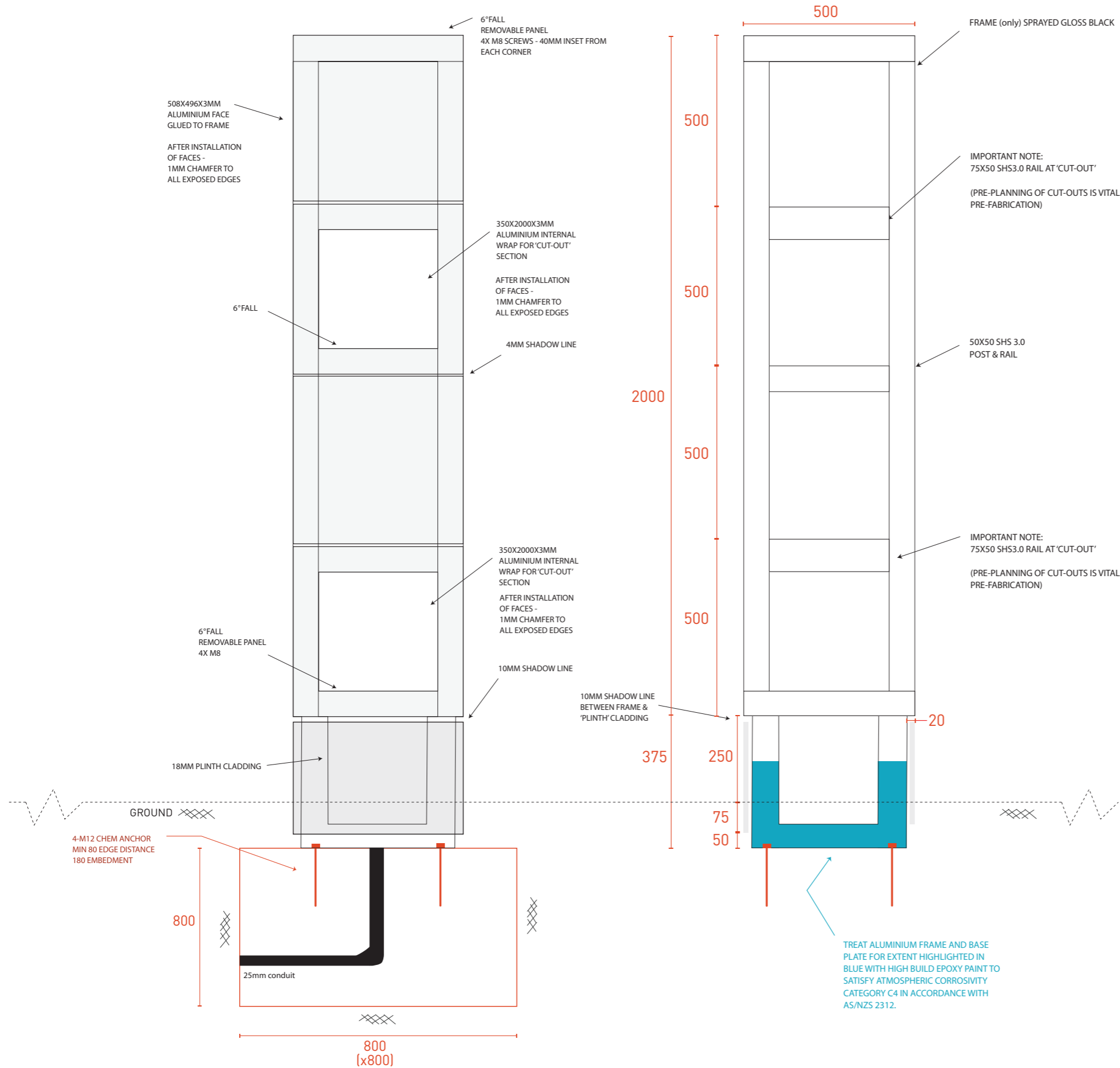

### BASE/PLINTH PERSPECTIVE

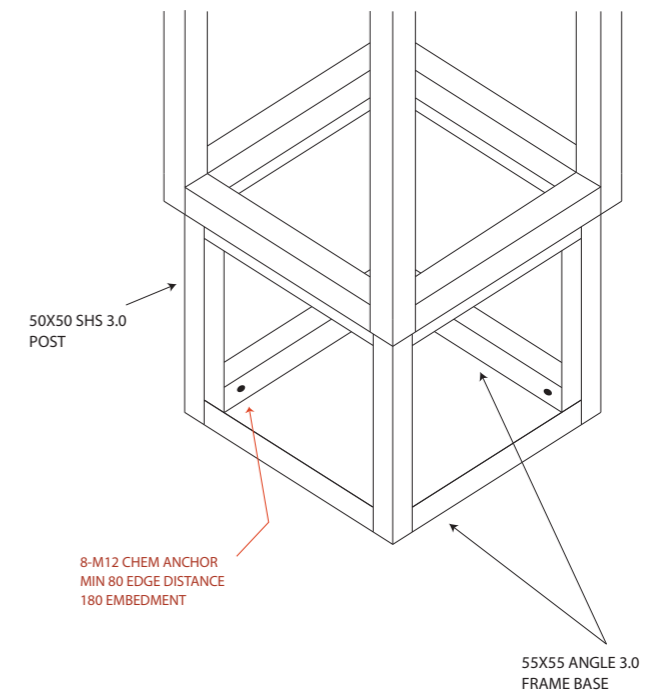

### GENERAL NOTES

- 1.0 CONCRETE PAD FOOTING
  - 1.1) ALL WORKMANSHIP AND MATERIALS SHALL BE IN ACCORDANCE WITH AS3600 CURRENT ADDITION WITH AMENDMENTS.
  - 1.2) PAD FOOTING TO BE N25 CONCRETE LAID ON COMPACTED SAND TO 95% M.M.D.D.
  - 1.3) PAD FOOTING TO BE LOCATED CENTRALLY UNDER FRAME.
- 2.0 ALUMINIUM
  - 2.1) ALL WORKMANSHIP AND MATERIALS SHALL BE IN ACCORDANCE WITH
    - AS/NZS 1866 EXTRUDED ROD, BAR, SOLID AND HOLLOW SHAPES
    - AS/NZS 1734 FLAT SHEET, COILED SHEET AND PLATE
    - AS/NZS 3715 THERMOSET POWDER COATING FOR ARCHITECTURAL APPLICATIONS
    - AS1664 STRUCTURAL USE OF ALUMINIUM
    - AS1665 WELDING OF ALUMINIUM STRUCTURES
  - 2.2) GRADE OF ALUMINIUM TO BE USED FOR SHS FRAME TO BE COMPATIBLE WITH BASE PLATE.

<p>SHAH KAKAHEL CIVIL/STRUCTURAL ENGINEER B.Eng, MIE(Aust) M: 0468 700 786 Email: info@aussiebuildings.com.au</p>	
<p>Dated: 09/05/2018</p>	<p>ShahKakakhel</p>

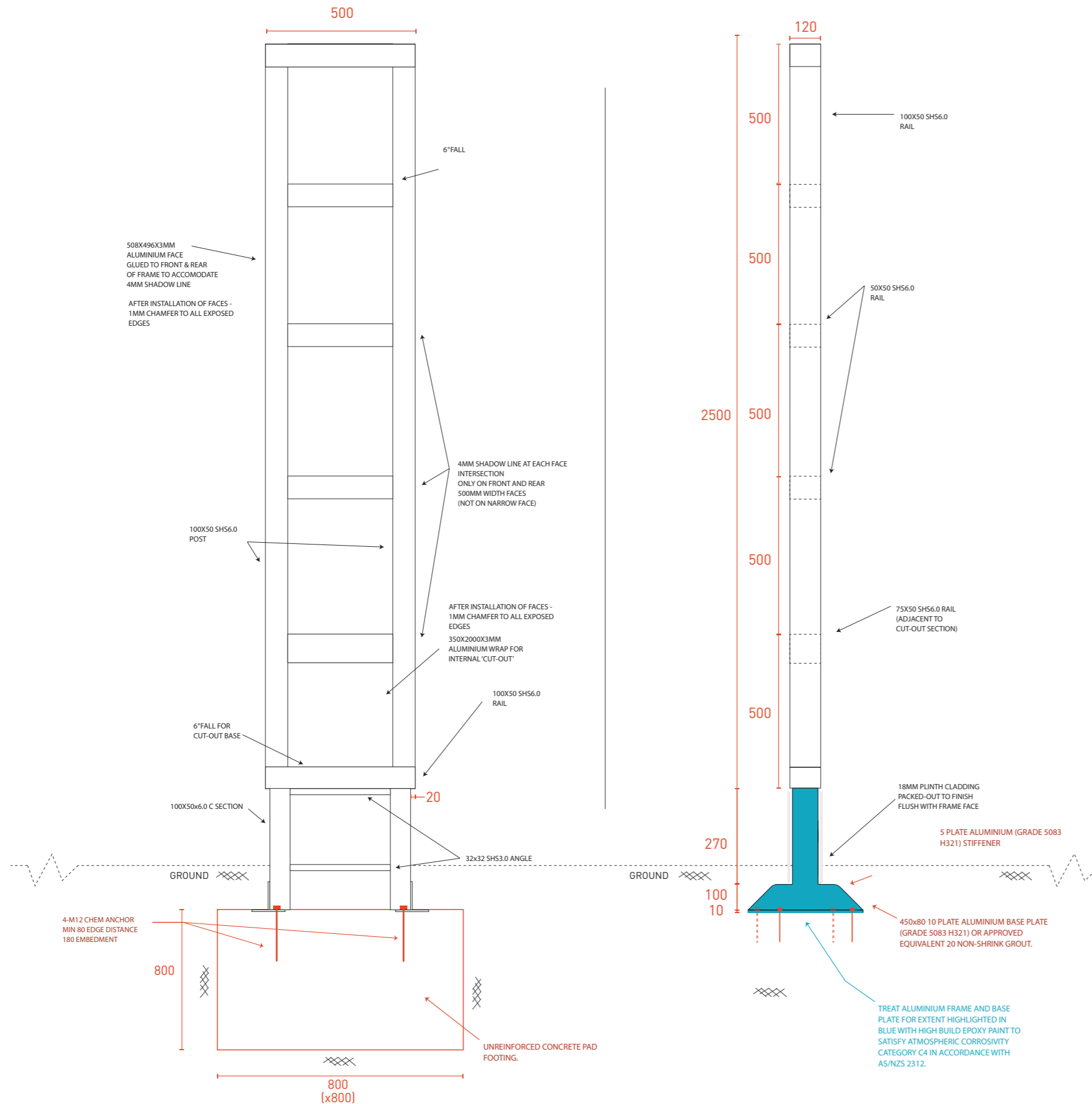

### BASE/PLINTH PERSPECTIVE

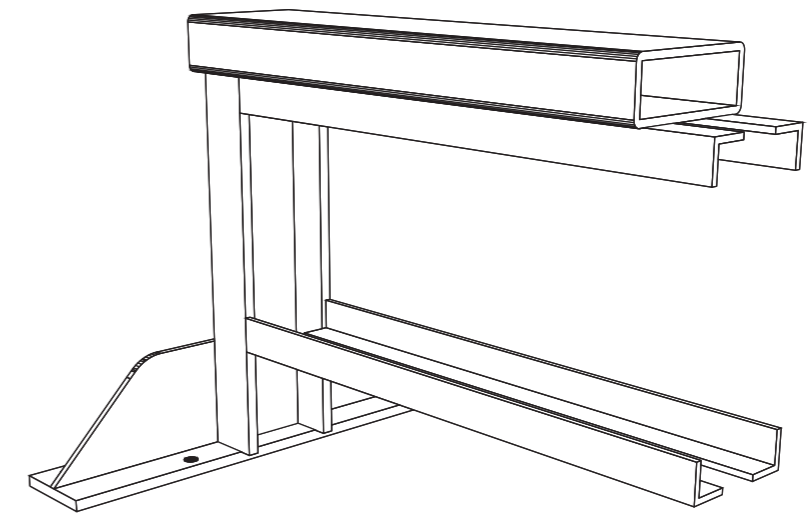

4-M12 CHEM ANCHOR  
MIN 80 EDGE DISTANCE  
180 EMBEDMENT

<p><b>SHAH KAKAHEL</b> CIVIL/STRUCTURAL ENGINEER B.Eng, MIE(Aust) M: 0468 700 786 Email: info@aussiebuildings.com.au</p>	<p> Aussie Building Specialists Fast Track Building Solutions</p>
<p>Dated: <b>09/05/2018</b></p>	<p><i>Shah Kakahel</i></p>

### GENERAL NOTES

- 1.0 CONCRETE PAD FOOTING
  - 1.1) ALL WORKMANSHIP AND MATERIALS SHALL BE IN ACCORDANCE WITH AS3600 CURRENT ADDITION WITH AMENDMENTS.
  - 1.2) PAD FOOTING TO BE N25 CONCRETE LAID ON COMPACTED SAND TO 95% M.M.D.D.
  - 1.3) PAD FOOTING TO BE LOCATED CENTRALLY UNDER FRAME.
- 2.0 ALUMINIUM
  - 2.1) ALL WORKMANSHIP AND MATERIALS SHALL BE IN ACCORDANCE WITH
    - AS/NZS 1866 EXTRUDED ROD, BAR, SOLID AND HOLLOW SHAPES
    - AS/NZS 1734 FLAT SHEET, COILED SHEET AND PLATE
    - AS/NZS 3715 THERMOSET POWDER COATING FOR ARCHITECTURAL APPLICATIONS
    - AS1664 STRUCTURAL USE OF ALUMINIUM
    - AS1665 WELDING OF ALUMINIUM STRUCTURES
  - 2.2) GRADE OF ALUMINIUM TO BE USED FOR SHS FRAME TO BE COMPATIBLE WITH BASE PLATE.

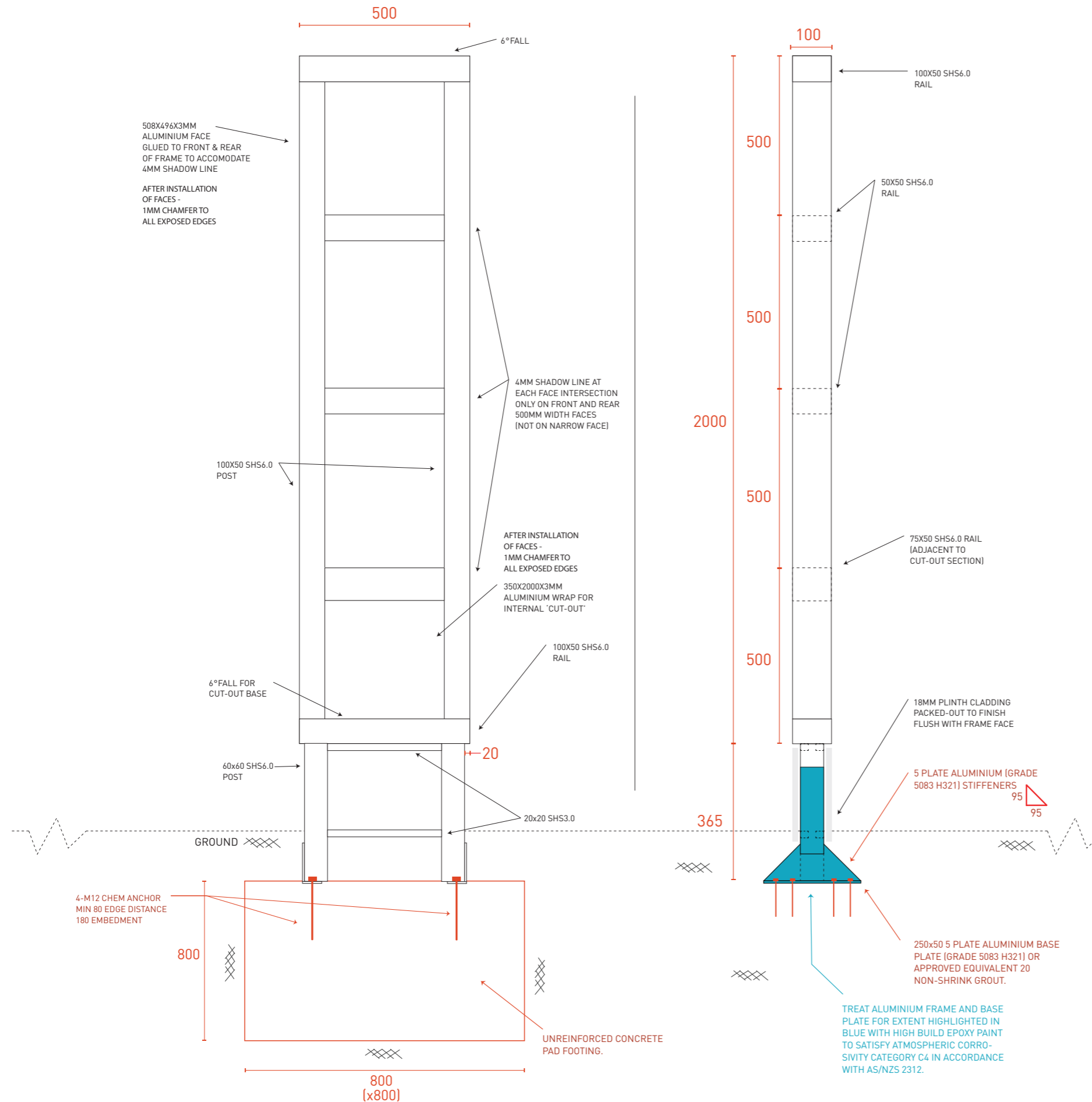

### BASE/PLINTH PERSPECTIVE

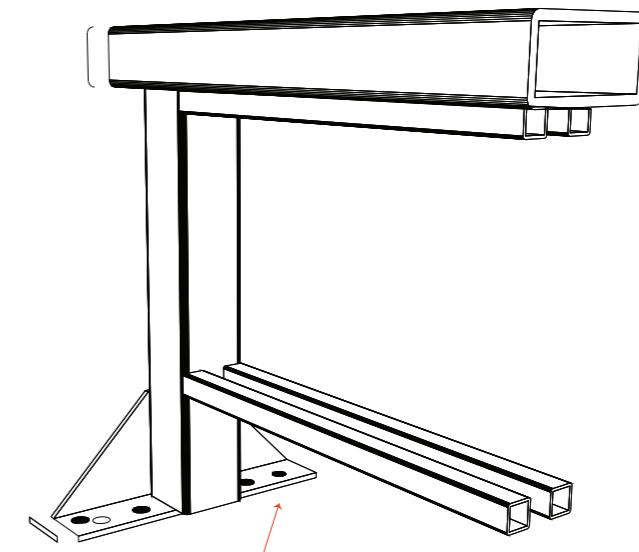

4-M12 CHEM ANCHOR  
MIN 80 EDGE DISTANCE  
180 EMBEDMENT

SHAH KAKAHEL  
CIVIL/STRUCTURAL ENGINEER  
B.Eng. MIE(Aust)  
M: 0468 700 786  
Email: info@aussiebuildings.com.au



Dated: 09/05/2018

ShahKakakel

### GENERAL NOTES

#### 1.0 CONCRETE PAD FOOTING

- 1.1) ALL WORKMANSHIP AND MATERIALS SHALL BE IN ACCORDANCE WITH AS3600 CURRENT ADDITION WITH AMENDMENTS.
- 1.2) PAD FOOTING TO BE N25 CONCRETE LAID ON COMPACTED SAND TO 95% M.M.D.D.
- 1.3) PAD FOOTING TO BE LOCATED CENTRALLY UNDER FRAME.

#### 2.0 ALUMINIUM

- 2.1) ALL WORKMANSHIP AND MATERIALS SHALL BE IN ACCORDANCE WITH
  - AS/NZS 1866 EXTRUDED ROD, BAR, SOLID AND HOLLOW SHAPES
  - AS/NZS 1734 FLAT SHEET, COILED SHEET AND PLATE
  - AS/NZS 3715 THERMOSET POWDER COATING FOR ARCHITECTURAL APPLICATIONS
  - AS1664 STRUCTURAL USE OF ALUMINIUM
  - AS1665 WELDING OF ALUMINIUM STRUCTURES
- 2.2) GRADE OF ALUMINIUM TO BE USED FOR SHS FRAME TO BE COMPATIBLE WITH BASE PLATE.

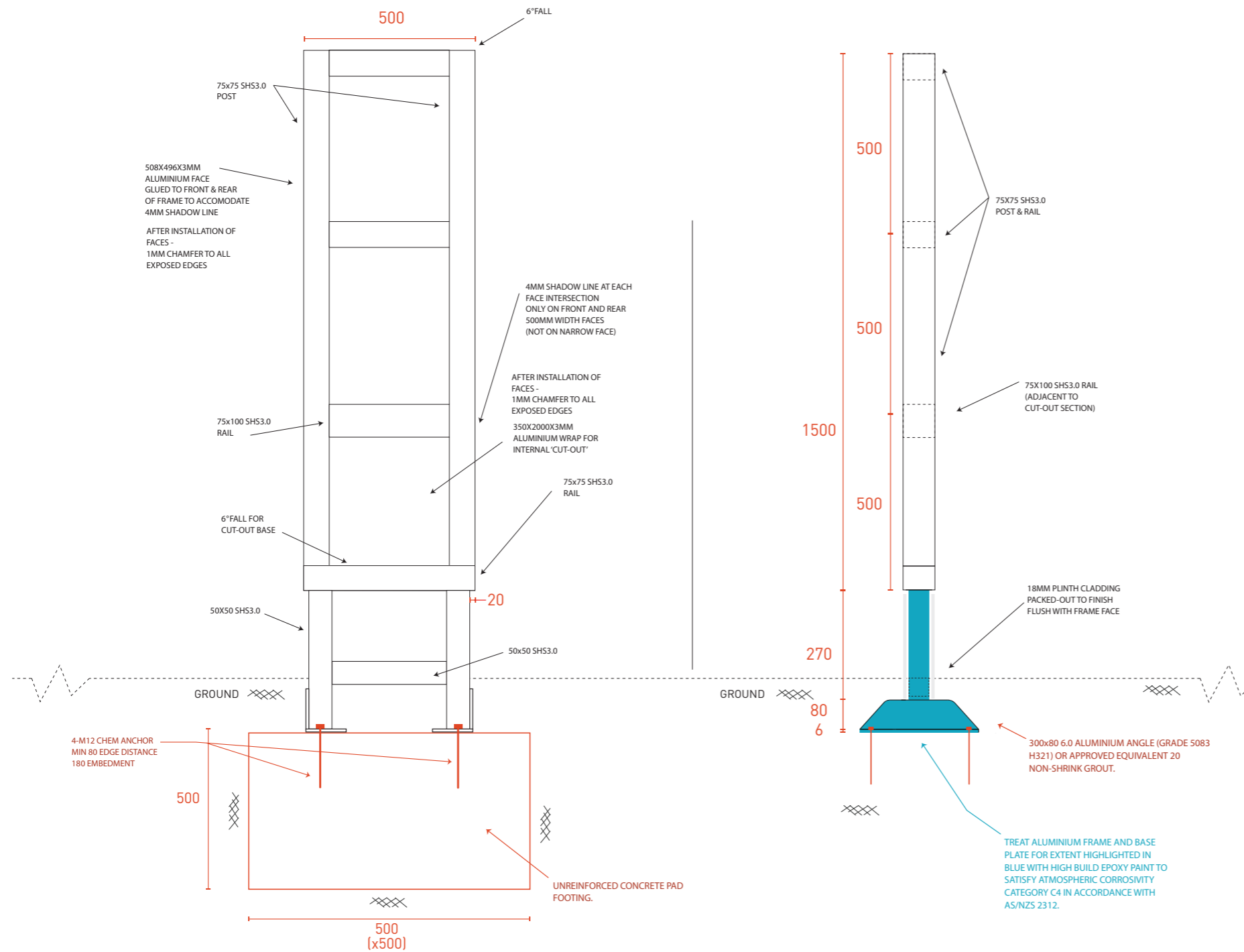

### BASE/PLINTH PERSPECTIVE

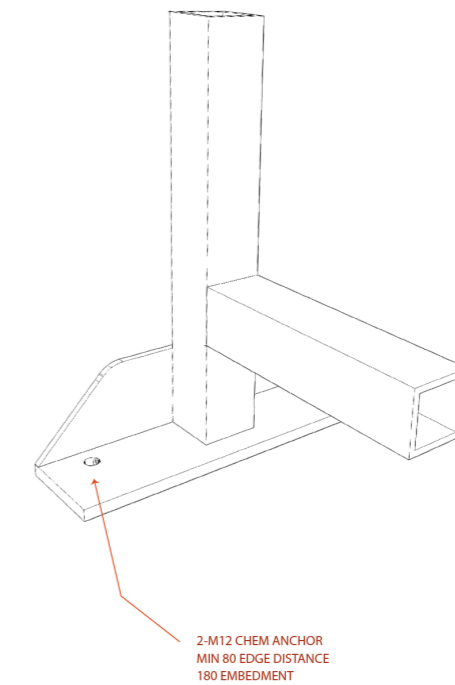

### GENERAL NOTES

#### 1.0 CONCRETE PAD FOOTING

- 1.1) ALL WORKMANSHIP AND MATERIALS SHALL BE IN ACCORDANCE WITH AS3600 CURRENT ADDITION WITH AMENDMENTS.
- 1.2) PAD FOOTING TO BE N25 CONCRETE LAID ON COMPACTED SAND TO 95% M.M.D.D.
- 1.3) PAD FOOTING TO BE LOCATED CENTRALLY UNDER FRAME.

#### 2.0 ALUMINIUM

- 2.1) ALL WORKMANSHIP AND MATERIALS SHALL BE IN ACCORDANCE WITH
  - AS/NZS 1866 EXTRUDED ROD, BAR, SOLID AND HOLLOW SHAPES
  - AS/NZS 1734 FLAT SHEET, COILED SHEET AND PLATE
  - AS/NZS 3715 THERMOSET POWDER COATING FOR ARCHITECTURAL APPLICATIONS
  - AS1664 STRUCTURAL USE OF ALUMINIUM
  - AS1665 WELDING OF ALUMINIUM STRUCTURES
- 2.2) GRADE OF ALUMINIUM TO BE USED FOR SHS FRAME TO BE COMPATIBLE WITH BASE PLATE.

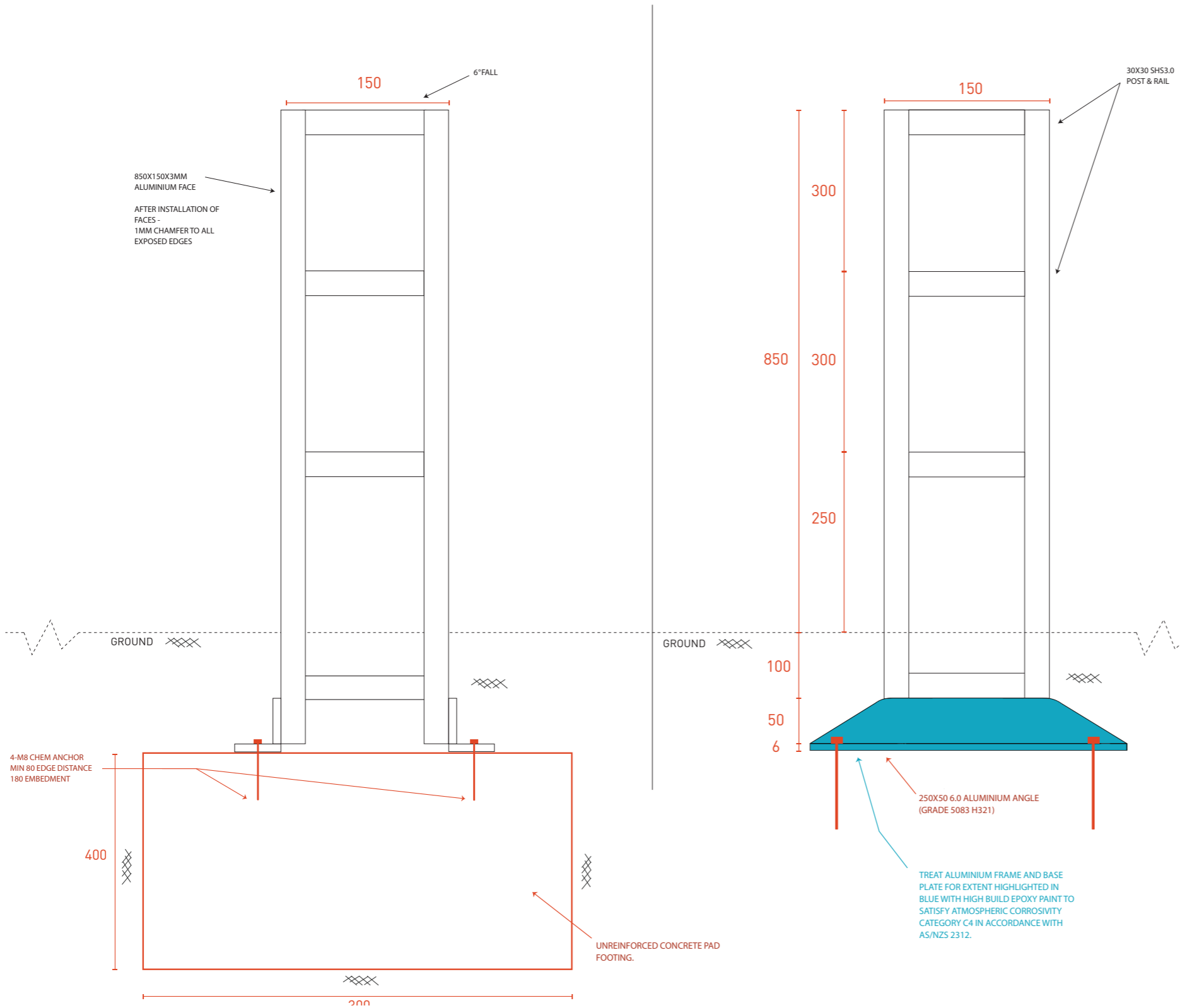

### BASE/PLINTH PERSPECTIVE

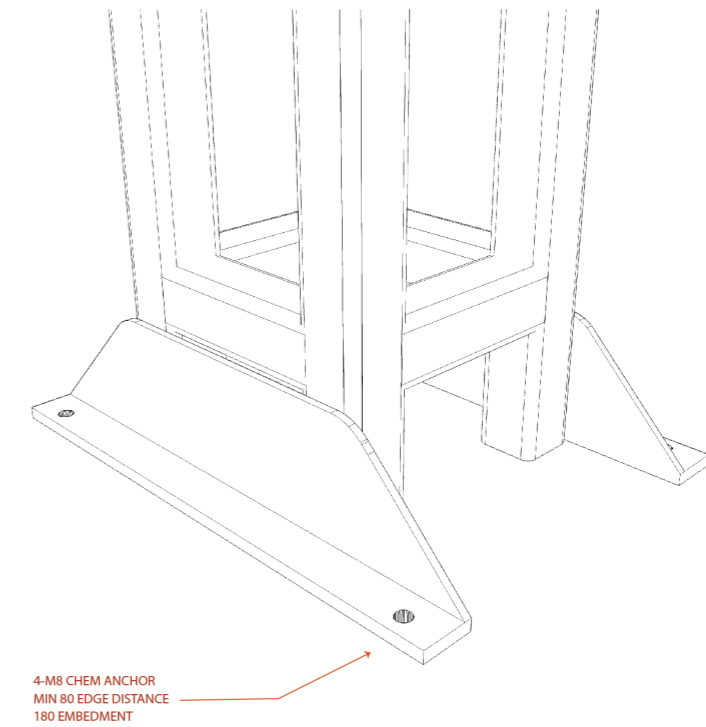

### GENERAL NOTES

- 1.0 CONCRETE PAD FOOTING
  - 1.1) ALL WORKMANSHIP AND MATERIALS SHALL BE IN ACCORDANCE WITH AS3600 CURRENT ADDITION WITH AMENDMENTS.
  - 1.2) PAD FOOTING TO BE N25 CONCRETE LAID ON COMPACTED SAND TO 95% M.M.D.D.
  - 1.3) PAD FOOTING TO BE LOCATED CENTRALLY UNDER FRAME.
- 2.0 ALUMINIUM
  - 2.1) ALL WORKMANSHIP AND MATERIALS SHALL BE IN ACCORDANCE WITH
    - AS/NZS 1866 EXTRUDED ROD, BAR, SOLID AND HOLLOW SHAPES
    - AS/NZS 1734 FLAT SHEET, COILED SHEET AND PLATE
    - AS/NZS 3715 THERMOSET POWDER COATING FOR ARCHITECTURAL APPLICATIONS
    - AS1664 STRUCTURAL USE OF ALUMINIUM
    - AS1665 WELDING OF ALUMINIUM STRUCTURES
  - 2.2) GRADE OF ALUMINIUM TO BE USED FOR SHS FRAME TO BE COMPATIBLE WITH BASE PLATE.

SHAH KAKAHEL  
CIVIL/STRUCTURAL ENGINEER  
B.Eng., MIE(Aust)  
M: 0468 700 786  
Email: info@aussiebuildings.com.au

Aussie Building Specialists  
Civil, Structural and Mechanical Engineers

Dated: 09/05/2018 *ShahKakakhel*

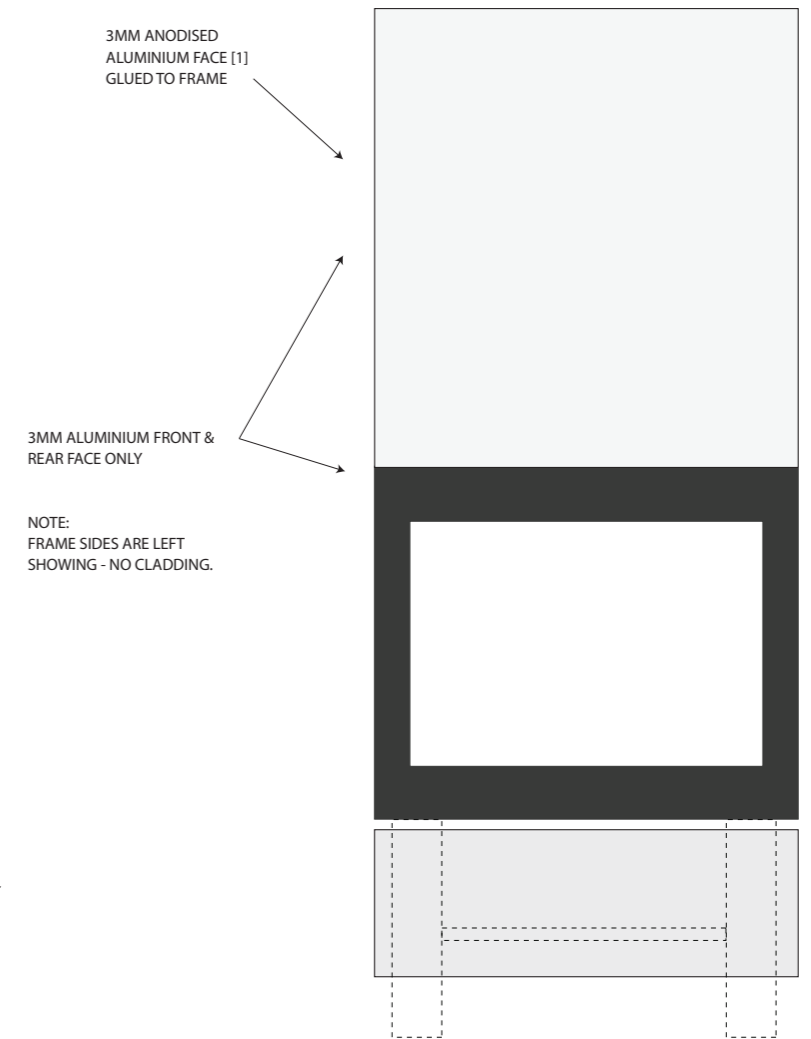
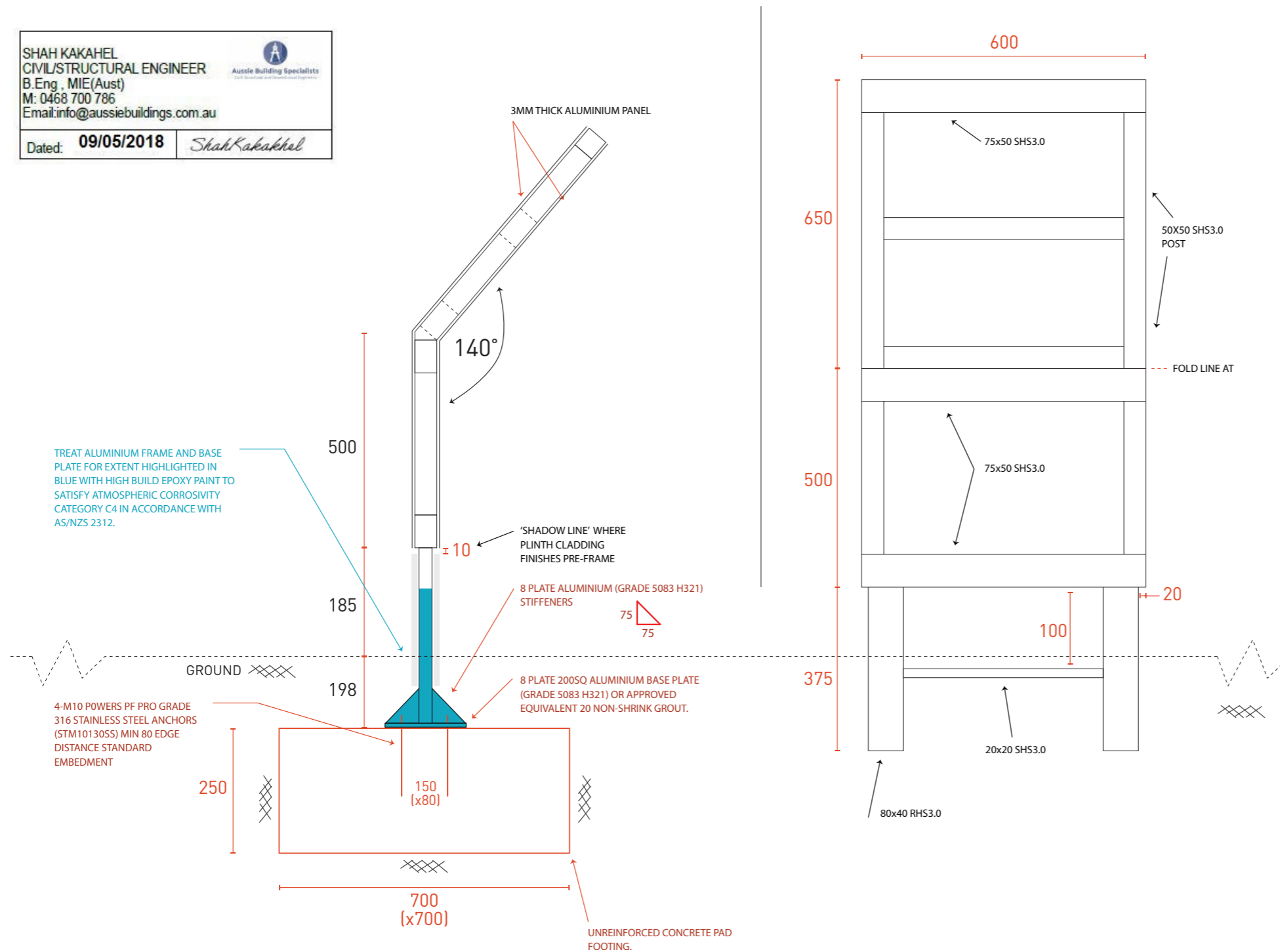

### GENERAL NOTES

- 1.0 CONCRETE PAD FOOTING
- 1.1) ALL WORKMANSHIP AND MATERIALS SHALL BE IN ACCORDANCE WITH AS3600 CURRENT ADDITION WITH AMENDMENTS.
- 1.2) PAD FOOTING TO BE N25 CONCRETE LAID ON COMPACTED SAND TO 95% M.M.D.D.
- 1.3) PAD FOOTING TO BE LOCATED CENTRALLY UNDER FRAME.

### 2.0 ALUMINIUM

- 2.1) ALL WORKMANSHIP AND MATERIALS SHALL BE IN ACCORDANCE WITH
  - AS/NZS 1866 EXTRUDED ROD, BAR, SOLID AND HOLLOW SHAPES
  - AS/NZS 1734 FLAT SHEET, COILED SHEET AND PLATE
  - AS/NZS 3715 THERMOSET POWDER COATING FOR ARCHITECTURAL APPLICATIONS
  - AS1664 STRUCTURAL USE OF ALUMINIUM
  - AS1665 WELDING OF ALUMINIUM STRUCTURES
- 2.2) GRADE OF ALUMINIUM TO BE USED FOR SHS FRAME TO BE COMPATIBLE WITH BASE PLATE.





# **SUPPORTING DOCUMENTATION**

**SPORT & RECREATION**

**URBAN**

**NATURAL  
'EPHEMERAL' / INLAND**

**COASTAL**

CENTENNIAL PARK  
STADIUMS  
RACE/MOTOR/BMX TRACKS

CBD

PARKS  
RESERVES

COASTAL WALKS  
BEACH  
PICNIC AREAS

Community  
Civic Pride  
Recreation  
Movement  
Health  
Passion / Energy  
Convergence / Gathering  
Celebration  
Collective Goals / Teamwork

Historical Buildings / Landmarks  
Harbour Views  
Community Hub  
Commercial Hub  
Civic Pride  
Creative / Arts  
Topography  
Convergence of People/Business

Exploration / Discovery  
Escape / Solitude  
Re-connect  
Community/Family  
Appreciation of Nature  
Convergence of People & Nature

Panoramic Views  
White Sand / Dunes  
Eroded Granite  
Wind / Rain  
Industrial Port  
Maritime Heritage  
Marine Recreation  
Natural Harbours  
Violent vs Serene Convergence of Land & Sea  
Exposure vs Protection

ADDITIONAL PRECINCT ZONES  
TO BE ADDRESSED AS SEPARATE PROJECT

**MOUNTS  
PRINCESS ROYAL FORTRESS  
HERITAGE**

500mm



500mm



VISITOR CENTRE



LIBRARY



RETAIL



CHURCH



PUBLIC TOILETS



POST OFFICE



ATM/BANK



SCHOOL/UNIVERSITY



UNIVERSAL ACCESS TOILETS



PARKING



GROCERIES



LOOKOUT



CHANGING PLACE



CHEMIST



CAFE



SKATEPARK



BABY FACILITIES



POLICE STATION



RESTAURANT



PLAYGROUND



SHOWER



DEFIBRILLATOR



PUB



DOGS PERMITTED



DRINKING FOUNTAIN



FIRST AID



COCKTAIL BAR



BBQ



**RAILWAYS**

Home of Railways Football & Sporting Club

TYPE 2a SLIM 600mm WIDTH  
FOOTBALL CLUB SIGNAGE  
CENTENNIAL PARK  
SIDE A + B



**Centennial Park**

**EASTERN PAVILION**

Home of Southern Districts Junior Football Association

Albany Cycle Club

Albany Triathlon Club

TYPE 2a SLIM  
EASTERN PAVILION  
CENTENNIAL PARK  
SIDE A



**Centennial Park**

- Toilets →
- Centennial Stadium ↑  
0.5 km / 6 mins
- Athletics Pavilion ↑  
1.2 km / 14 mins
- Albany Leisure & Aquatic Centre ↑  
1.4 km / 17 mins
- Western Pavilion ↑  
1.5 km / 18 mins



These grounds are SMOKE-FREE during sporting games, events and training  
Please use the Smoking Areas provided

TYPE 2a SLIM  
EASTERN PAVILION  
CENTENNIAL PARK  
SIDE B



**Stirling Terrace**

- City Centre ↑  
0.6 km / 9 mins
- Visitor Centre ↑  
0.6 km / 9 mins
- Public Toilets ←  
0.2 km / 2 mins
- Museum of WA & Brig Amity ←  
0.7 km / 8 mins





TYPE 2a SLIM  
STIRLING TERRACE  
WAYFINDING  
SIDE A



**Stirling Terrace**

- Albany Town Hall →  
0.9 km / 9 mins
- Town Square →  
0.6 km / 9 mins
- Over Footbridge:
- Entertainment Precinct Waterfront Marina ↑  
0.5 km / 6 mins
- Port Passenger Terminal ↑  
1.3 km / 16 mins
- Lawley Park ←  
0.6 km / 7 mins
- Port to Point Trail Head ←  
2.5 km / 30 mins
- Albany Heritage Park & National Anzac Centre ←  
2.8 km / 36 mins



TYPE 2a SLIM  
STIRLING TERRACE  
WAYFINDING  
SIDE B



**Visitor Information**

KAIA KAIA  
MENANG BOODJA

WELCOME TO  
MENANG COUNTRY

TYPE 2a SLIM  
ALBANY VISITOR CENTRE  
CITY CENTRE  
SIDE A



**Opening Times**

**SUMMER (1 NOV-31 MAR)**  
Monday-Friday 6am-9pm  
Saturday 8am-5pm  
Sunday 9am-4pm

**WINTER (1 APR-31 OCT)**  
Monday-Friday 6am-8pm  
Saturday 8am-5pm  
Sunday 10am-3pm

Public Holidays (all year) 10am-3pm  
Closed Good Friday & Christmas Day

Telephone 6820 3400

This venue and grounds are SMOKE-FREE at all times  
Please use the Smoking Areas provided



TYPE 2b SLIM  
ALAC ENTRY SIGN  
CENTENNIAL PARK  
SIDE A + B

**Changing Places**

This facility is for eligible users. It is part of a state-wide network fitted with a unique locking system.

To find out if you are eligible to use Changing Places facilities, please contact the City of Albany on 6820 3000.

For emergencies please call the City of Albany call centre on 1800 633 000.

For location of standard accessible public toilets and baby change facilities, please refer to the map.

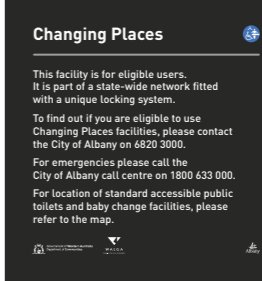
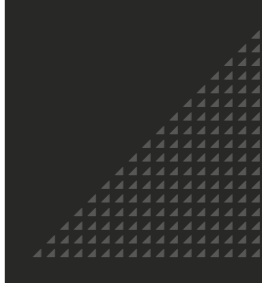
TYPE 2c SLIM  
CHANGING PLACE  
ALBANY WATERFRONT  
SIDE A

- Albany Entertainment Centre →
- Visitor Centre ↖
- Anzac Peace Park ↖

TYPE 2c SLIM  
CHANGING PLACE  
ALBANY WATERFRONT  
SIDE B

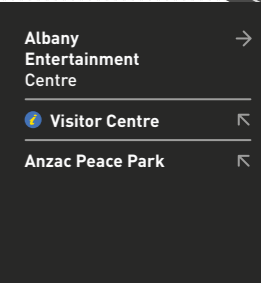

TYPE 2d FIELD MARKER  
MULTI PURPOSE SPORTING FIELD  
CENTENNIAL PARK



TYPE 3 FOOTPATH SIGN  
CHANGING PLACE  
ALBANY WATERFRONT



TYPE 4a LECTURN  
NOONGAR INTERPRETATION  
MIDDLETON BEACH BOARDWALK



TYPE 4a LECTURN  
HERITAGE INTERPRETATION  
COASTAL WALK TRAIL



TYPE 4b MINI LECTURNS  
NOONGAR INTERPRETATION  
MOKARE PROJECT  
ALISON HARTMAN GARDENS

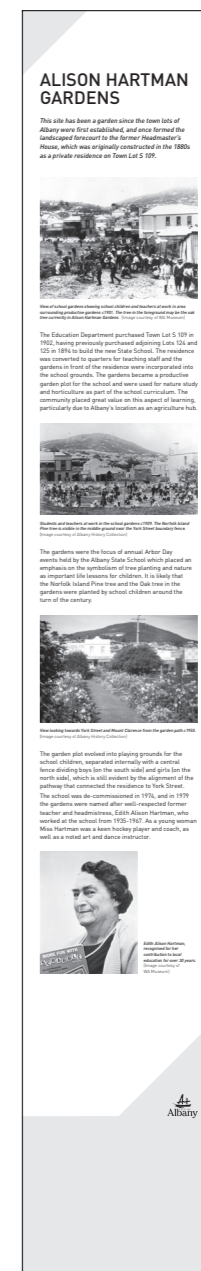

ALISON HARTMAN GARDENS  
INTERPRETATION  
SIDE A



ALISON HARTMAN GARDENS  
INTERPRETATION  
SIDE B